

3-2. L 防火壁 Firewall

準備工作 Preparation

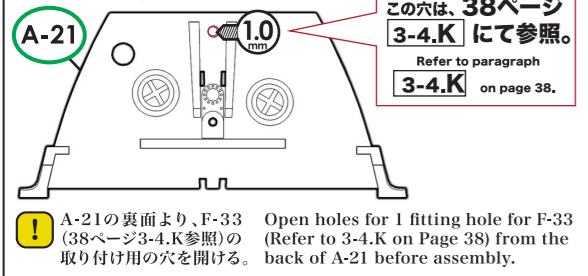

! A-21の裏面より、F-33 (38ページ3-4.K参照)の取り付け用の穴を開ける。 Open holes for 1 fitting hole for F-33 (Refer to 3-4.K on Page 38) from the back of A-21 before assembly.

実機におけるパーツ名
Name of the parts implemented
in the actual aircraft.

- A-21 防火壁
Firewall
- Q-10 MG 17 架台
MG 17 Shelf

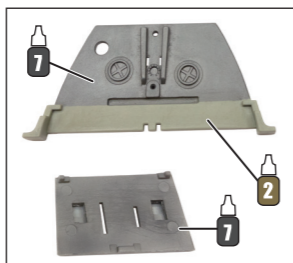

各パーツ接着位置 Parts configuration after assembly.

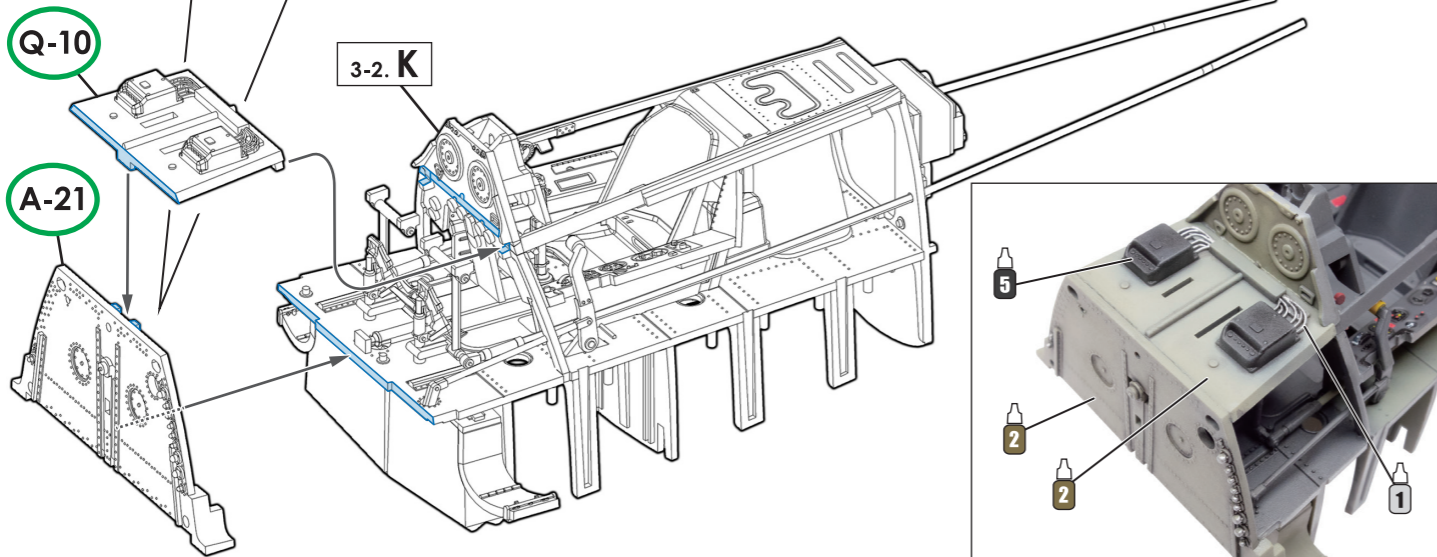
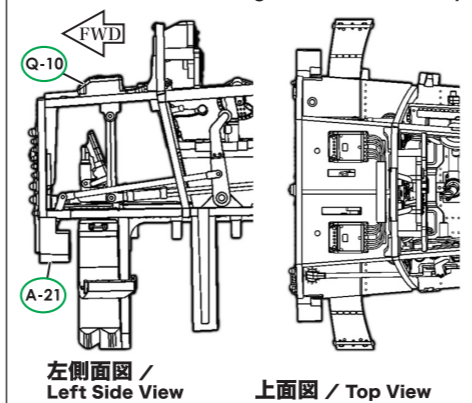

3-2. M 燃料タンク Fuel Tank

実機におけるパーツ名
Name of the parts implemented in the actual aircraft.

- C-13 C-15 前部燃料タンク
Front Fuel Tank
- C-12 C-14 後部燃料タンク
Rear Fuel Tank

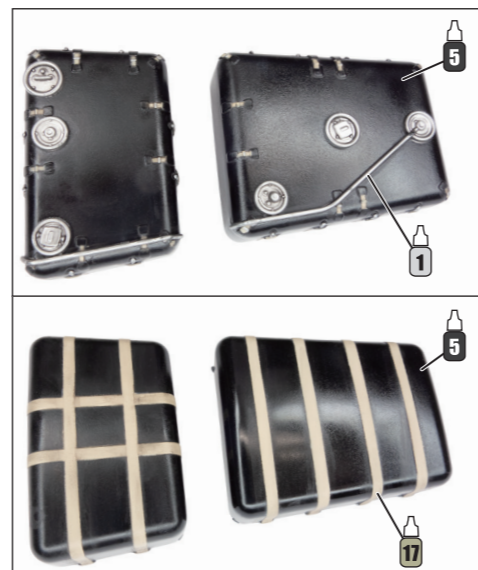
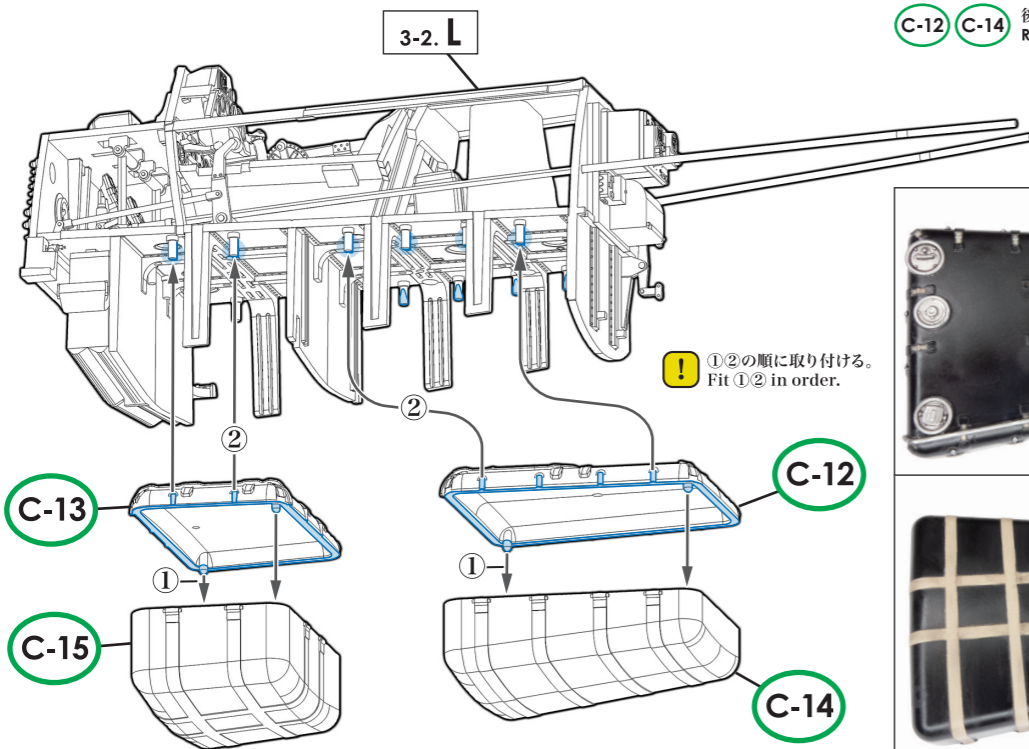

各パーツ接着位置 Parts configuration after assembly.

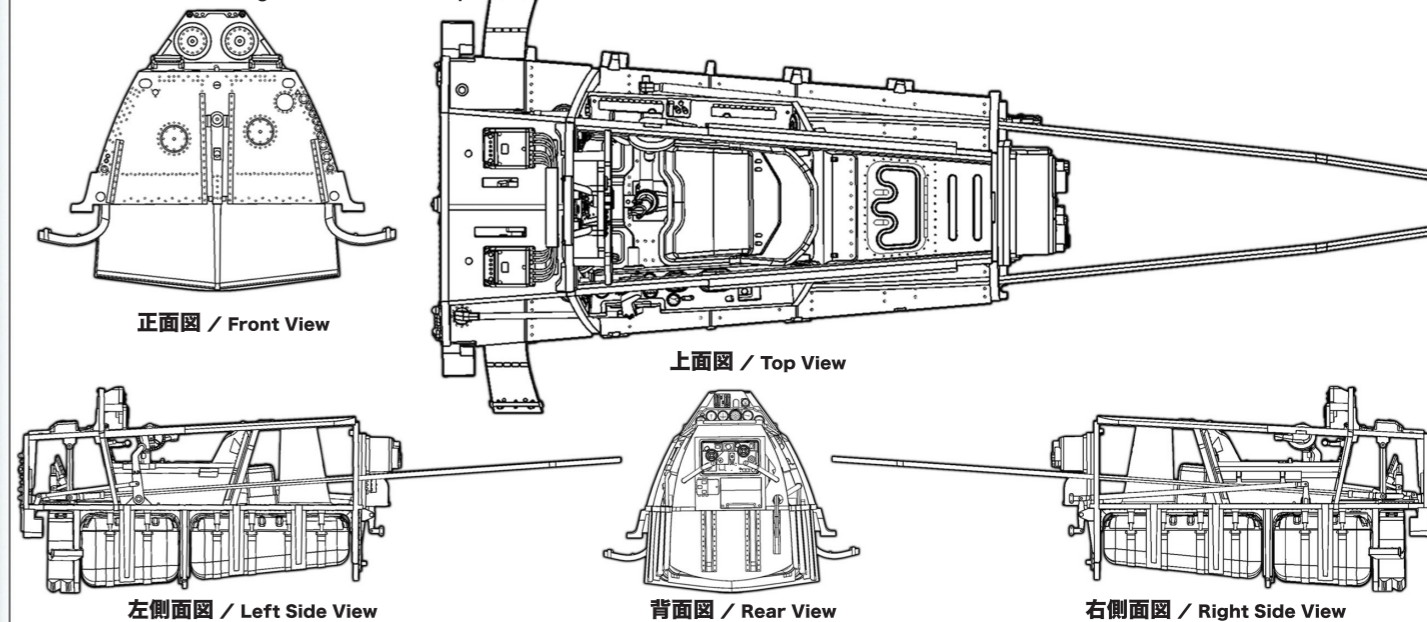

下記写真は、3-2.を項目ごとに組み立てた状態を示しています。
The photographs below illustrate the completed parts of chapter 3-2.

